



Visualisation; Diagnostics

Easy to Configure

Programming IEC 61131-3

Rapid Installation

PSEN ma1.3-22 M12/8 VA

PILZ

THE SPIRIT OF SAFETY

► PSEN sensor technology

This document is the original document.

All rights to this documentation are reserved by Pilz GmbH & Co. KG. Copies may be made for the user's internal purposes. Suggestions and comments for improving this documentation will be gratefully received.

Source code from third-party manufacturers or open source software has been used for some components. The relevant licence information is available on the Internet on the Pilz homepage.

Pilz®, PIT®, PMI®, PNOZ®, Primo®, PSEN®, PSS®, PVIS®, SafetyBUS p®, SafetyEYE®, SafetyNET p®, the spirit of safety® are registered and protected trademarks of Pilz GmbH & Co. KG in some countries.



SD means Secure Digital

Introduction	4
Validity of documentation	4
Using the documentation	4
Definition of symbols	4
Safety	5
Intended use	5
Safety regulations	5
Safety assessment	5
Use of qualified personnel	6
Warranty and liability	6
Disposal	6
For your safety	7
Unit features	7
Function description	7
Block diagram	8
Operating distances	8
Lateral and vertical offset	9
Wiring	9
Pin assignment	10
Requirements and connection to evaluation devices	10
Installation	14
Adjustment	17
Periodic test	17
Dimensions in mm	18
Technical details	18
Safety characteristic data	20
Supplementary data	20
Technical details PSEN ix0 F1 mag	20
Order reference	21
System	21
Accessories	22
EC declaration of conformity	22

Introduction

Validity of documentation

This documentation is valid for the product PSEN ma1.3-22 M12/8 VA. It is valid until new documentation is published.

This operating manual explains the function and operation, describes the installation and provides guidelines on how to connect the product.

Using the documentation

This document is intended for instruction. Only install and commission the product if you have read and understood this document. The document should be retained for future reference.

Definition of symbols

Information that is particularly important is identified as follows:



DANGER!

This warning must be heeded! It warns of a hazardous situation that poses an immediate threat of serious injury and death and indicates preventive measures that can be taken.



WARNING!

This warning must be heeded! It warns of a hazardous situation that could lead to serious injury and death and indicates preventive measures that can be taken.



CAUTION!

This refers to a hazard that can lead to a less serious or minor injury plus material damage, and also provides information on preventive measures that can be taken.



NOTICE

This describes a situation in which the product or devices could be damaged and also provides information on preventive measures that can be taken. It also highlights areas within the text that are of particular importance.

**INFORMATION**



This gives advice on applications and provides information on special features.

Safety**Intended use**

The safety function of the safety switch is:

- ▶ Safe detection of the magnetic actuator within the response range

The safety switch meets the requirements in accordance with:

- ▶ EN 60947-5-3 in series connections: PDDB only in connection
 - with the actuator PSEN ma1.3-08 VA,
 - the interface PSEN ix1 and
 - the suitable evaluation devices (see [Requirements and connection to evaluation devices](#) [ 10]).
- ▶ EN 60947-5-3 in single connections: PDDB only in connection
 - with the actuator PSEN ma1.3-08 VA,
 - the control cabinet terminal PSEN ix0 F1 mag (see [Order reference for accessories](#) [ 22]) and
 - the suitable evaluation devices.

The following is deemed improper use in particular

- ▶ Any component, technical or electrical modification to the product,
- ▶ Use of the product outside the areas described in this manual,
- ▶ Use of the product outside the technical details (see [Technical details](#) [ 18]).

**NOTICE****EMC-compliant electrical installation**

The product is designed for use in an industrial environment. The product may cause interference if installed in other environments. If installed in other environments, measures should be taken to comply with the applicable standards and directives for the respective installation site with regard to interference.

Safety regulations**Safety assessment**

Before using a device it is necessary to perform a safety assessment in accordance with the Machinery Directive.

Functional safety is guaranteed for the product as a single component. However, this does not guarantee the functional safety of the overall plant/machine. In order to achieve the required safety level for the overall plant/machine, define the safety requirements for the plant/machine and then define how these must be implemented from a technical and organisational standpoint.

Use of qualified personnel

The products may only be assembled, installed, programmed, commissioned, operated, maintained and decommissioned by competent persons.

A competent person is a qualified and knowledgeable person who, because of their training, experience and current professional activity, has the specialist knowledge required. To be able to inspect, assess and operate devices, systems and machines, the person has to be informed of the state of the art and the applicable national, European and international laws, directives and standards.

It is the company's responsibility only to employ personnel who

- ▶ Are familiar with the basic regulations concerning health and safety / accident prevention,
- ▶ Have read and understood the information provided in the section entitled Safety
- ▶ Have a good knowledge of the generic and specialist standards applicable to the specific application.

Warranty and liability

All claims to warranty and liability will be rendered invalid if

- ▶ The product was used contrary to the purpose for which it is intended,
- ▶ Damage can be attributed to not having followed the guidelines in the manual,
- ▶ Operating personnel are not suitably qualified,
- ▶ Any type of modification has been made (e.g. exchanging components on the PCB boards, soldering work etc.).

Disposal

- ▶ In safety-related applications, please comply with the mission time T_M in the safety-related characteristic data.
- ▶ When decommissioning, please comply with local regulations regarding the disposal of electronic devices (e.g. Electrical and Electronic Equipment Act).

For your safety**WARNING!****Loss of safety function due to manipulation of the interlocking device**

Manipulation of the interlocking device may lead to serious injury and death.

- You should prevent any possibility of the interlocking device being manipulated through the use of a spare actuator.
- Keep the substitute actuator in a safe place and protect it from unauthorised access.
- If spare actuators are used, these must be installed as described in [Installation](#) [ 15].
- If the original actuators are replaced with substitute actuators, the original actuators must be destroyed before disposal.



- ▶ Do not remove the connector's protective cap until you are just about to connect the unit. This will prevent potential contamination.

Unit features

- ▶ The actuator PSEN ma1.3-08 VA belongs to the safety switch.
- ▶ Coded actuator
- ▶ Safety switch with 8-pin M12 male connector
- ▶ Use with temperatures over 80 °C
- ▶ 2 safety contacts (reed contacts - N/O)
- ▶ 1 auxiliary contact (N/O)
- ▶ Design: cylindrical with threaded sleeve
 - Safety switch M12
 - Actuator M12: PSEN ma1.3-08 VA
- ▶ Operation Magnetic
- ▶ Switching voltage 24 VDC
- ▶ Series connection via PSEN ix1 interface
- ▶ Switch and actuator from stainless steel

Function description**Application in series connections**

Operate the PSEN ma1.3-22 M12/8 VA in conjunction with the following components:

- ▶ Actuator PSEN ma1.3-08 VA (see [Order reference](#) [ 21]),
- ▶ interface PSEN ix1 (see [Order reference](#) [ 22]) and
- ▶ a connected evaluation device (see [Requirements and connection to evaluation devices](#) [ 10]).

Application in single connections

Operate the PSEN ma1.3-22 M12/8 VA in conjunction with the following components:

- ▶ Actuator PSEN ma1.3-08 VA,
- ▶ Control cabinet terminal PSEN ix0 F1 mag (see [Order reference \[22\]](#)) and
- ▶ a connected evaluation device.

If the actuator is within the response range (safety gate closed), the safety contacts and the auxiliary contact on the safety switch are closed.

Block diagram

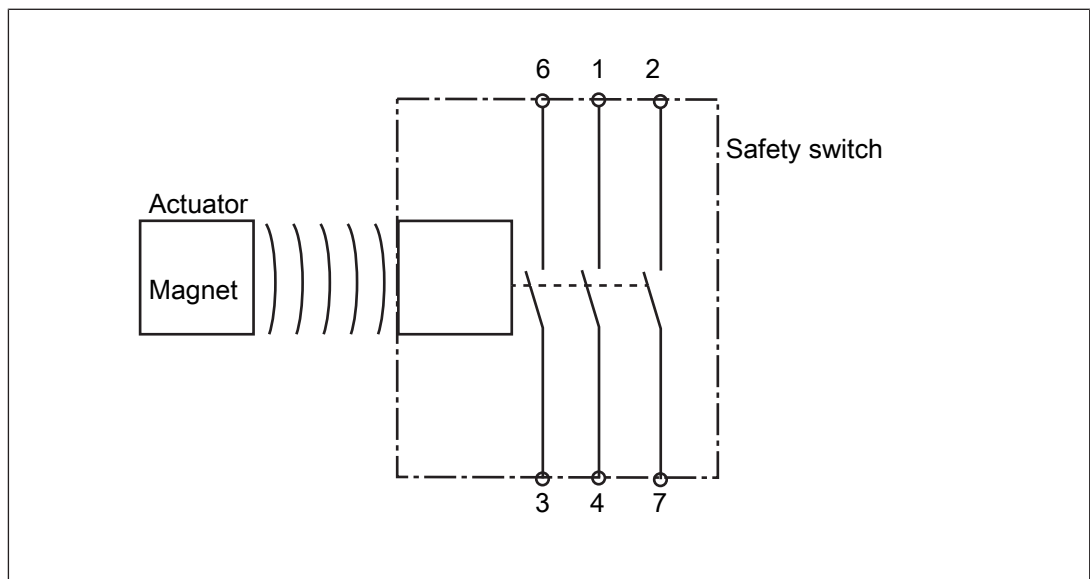

Operating distances

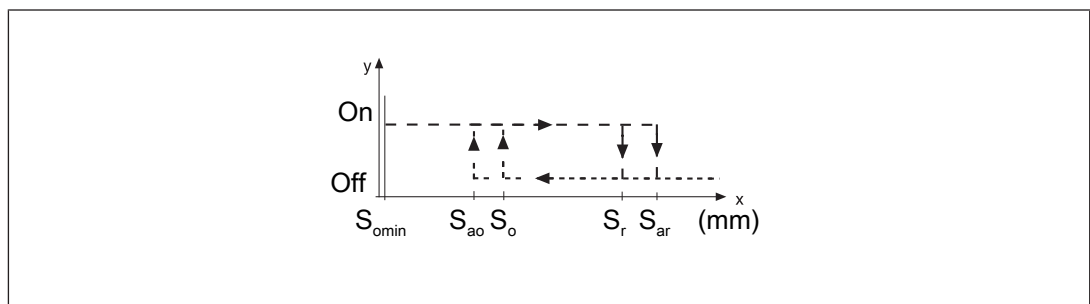

Legend

- S_{ao} Assured operating distance
- S_{omin} Min. operating distance
- S_{ar} Assured release distance

The offset-independent values for the switching distances are included in the [Technical details \[18\]](#).

Lateral and vertical offset

Actuator PSEN ma1.3-08/VA

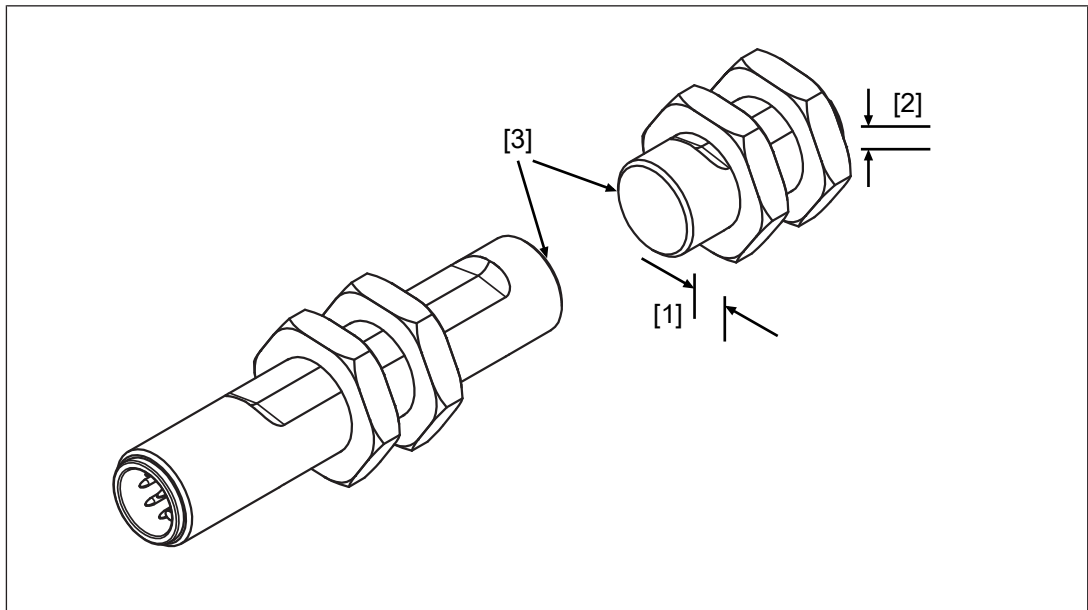

Legend

- [1] Lateral offset
- [2] Vertical offset
- [3] Sensing faces

Assured operating distance S_{ao} in mm

Lateral offset	Vertical offset		
	0	2	4
0	8.0	7.2	5.8
2	7.2	6.6	5.1
4	5.8	5.1	3.2

The stated values are valid at a temperature of 20 °C.

Wiring

- ▶ Information given in the [Technical details \[18\]](#) must be followed.
- ▶ Calculation of the max. cable length l_{max} :

$$l_{max} = \frac{R_{lmax} - R_i}{R_l / km}$$

R_{lmax} = Max. overall cable resistance (see evaluation device's technical details)

R_i = Internal resistance sensor (see [Technical details \[18\]](#))

R_l / km = Cable resistance/km of the cable (see technical details cable)

- ▶ Ensure the wiring and EMC requirements of EN 60204-1 are met.

- ▶ Depending on which evaluation device is used, the overall cable resistance must be checked; before commissioning it may also be necessary to check the cross circuit detection function.

Perform the checks as described in the operating manual for the evaluation device.

- ▶ The supply voltage for the auxiliary contact must be provided via a Class III power supply.
- ▶ The safety contacts are not short circuit-proof.
- ▶ UL requirement: the supply voltage must be provided via a Class 2 power supply.

Pin assignment



NOTICE

The colour marking for the connection lead only applies for the cable that Pilz supplies as an accessory

The safety switch is shown in an unoperated condition.

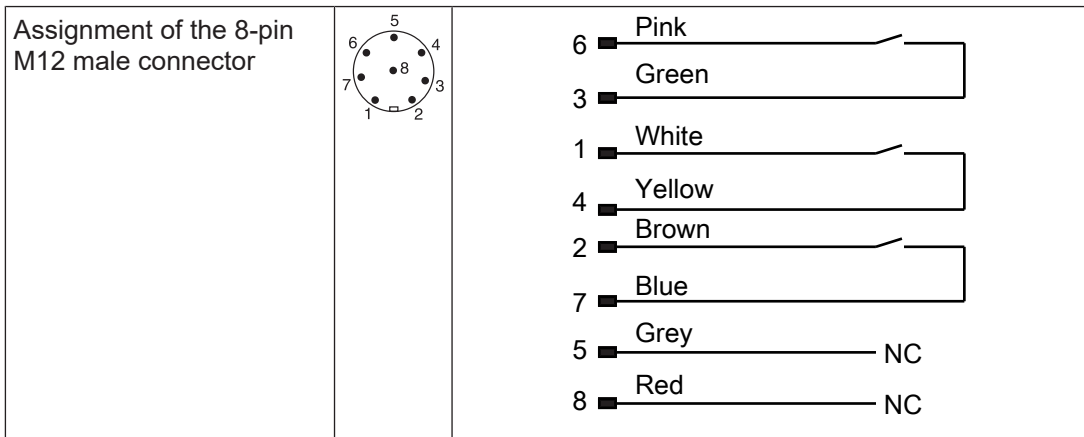

NOTICE

The auxiliary contact (pin 2, pin 7)

- can be connected in series
- may **not** be used for safety circuits

Requirements and connection to evaluation devices

For use of PSEN ma1.3-22 M12/8 VA in accordance with DIN EN 60947-5-3 an evaluation device must be connected.

Connect the PSEN ma1.3-22 M12/8 VA

- ▶ **either** with a certified Pilz evaluation device
- ▶ **or** with an evaluation device with defined properties

Certified Pilz evaluation devices are, for example:

- ▶ PNOZelog for safety gate monitoring
 - PNOZ e1p, PNOZ e1.1p, PNOZ e1vp
 - PNOZ e5.11p
 - PNOZ e6vp, PNOZ e6.1p
- ▶ PNOZpower for safety gate monitoring
 - PNOZ p1p, PNOZ p1vp
- ▶ PNOZsigma for safety gate monitoring:
 - PNOZ s3
 - PNOZ s4
 - PNOZ s5
- ▶ PNOZ X for safety gate monitoring
 - PNOZ X2, PNOZ X2.5P, PNOZ X2.7P, PNOZ X2.8P, PNOZ X2.9P, PNOZ X2C
 - PNOZ X3, PNOZ X3.1, PNOZ X3P, PNOZ X3.10P
 - PNOZ X4
 - PNOZ X5, PNOZ X5J
 - PNOZ Ex
- ▶ PNOZmulti for safety gate monitoring
Configure the switch in the PNOZmulti Configurator with switch type 3.
- ▶ PSS for safety gate monitoring with standard function block SB064, SB066 or FS_Safety Gate
- ▶ PSSuniversal PLC for safety gate monitoring with function block FS_SafetyGate

The correct connection to the respective evaluation device is described in the operating manual for the evaluation device. Make sure that the connection is made in accordance with the specifications in the operating manual for the selected evaluation device.

Defined properties of evaluation devices:

- ▶ 2-channel with feasibility monitoring
- ▶ Open circuit monitoring of the safety switch is performed
- ▶ Inputs and outputs on the evaluation device must fulfil the requirements of IEC 61131, Type 3
- ▶ Technical data of the evaluation device must fulfil the requirements in the [Technical details \[18\]](#) of PSEN ma1.3-22 M12/8 VA
 - Always comply with the max. switching current safety contacts of PSEN ma1.3-22 M12/8 VA.
- ▶ Outputs at the evaluation device must only be switched on again when both reed contacts at the safety switch have been opened and closed (partial operation lock)



INFORMATION

Risk time in accordance with DIN EN 60947-5-3

The risk time is made up of the reaction time of the sensor (see [Technical details \[18\]](#)) and the processing and delay times of the evaluation device (s. operating manual for the relevant evaluation device).

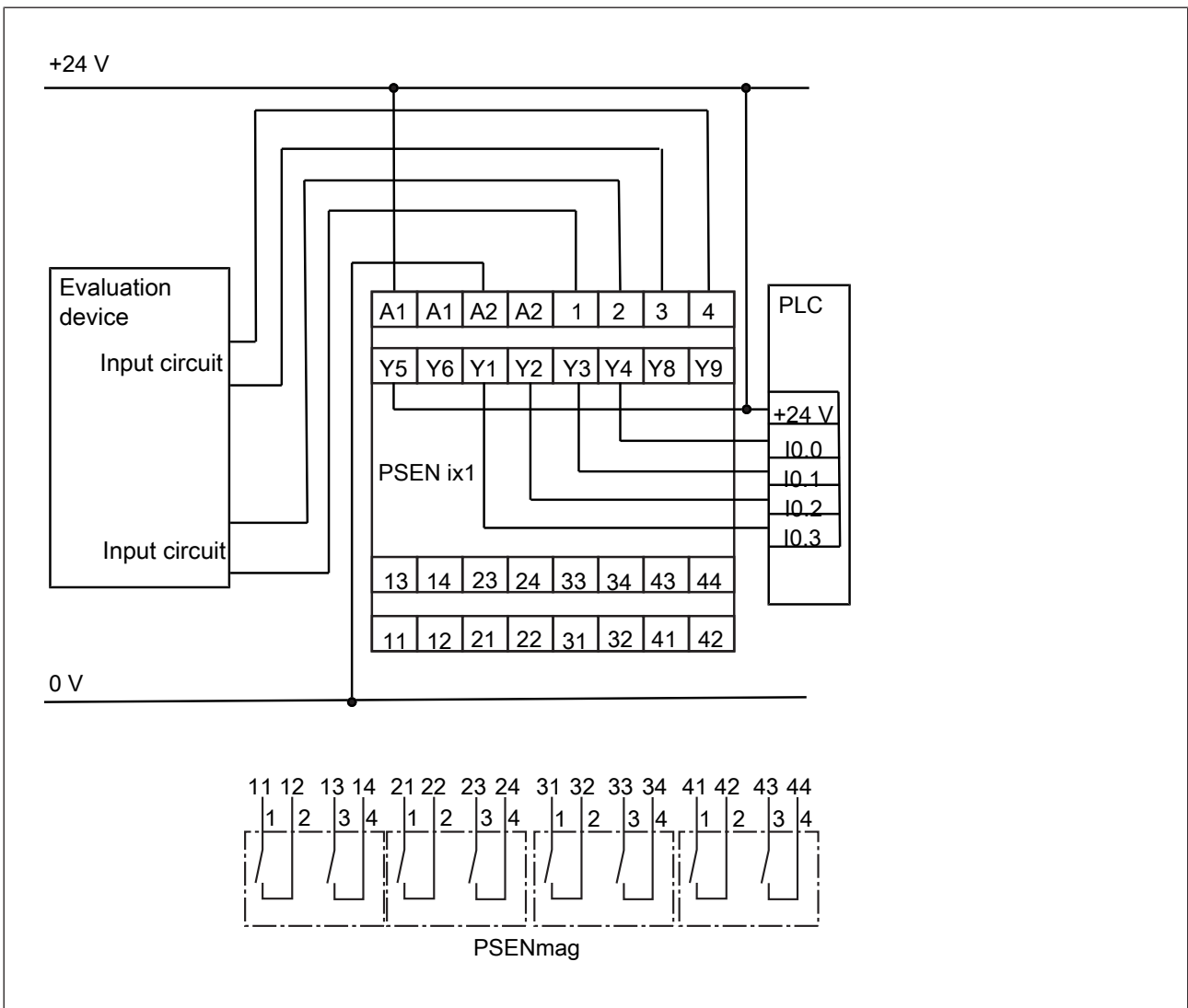
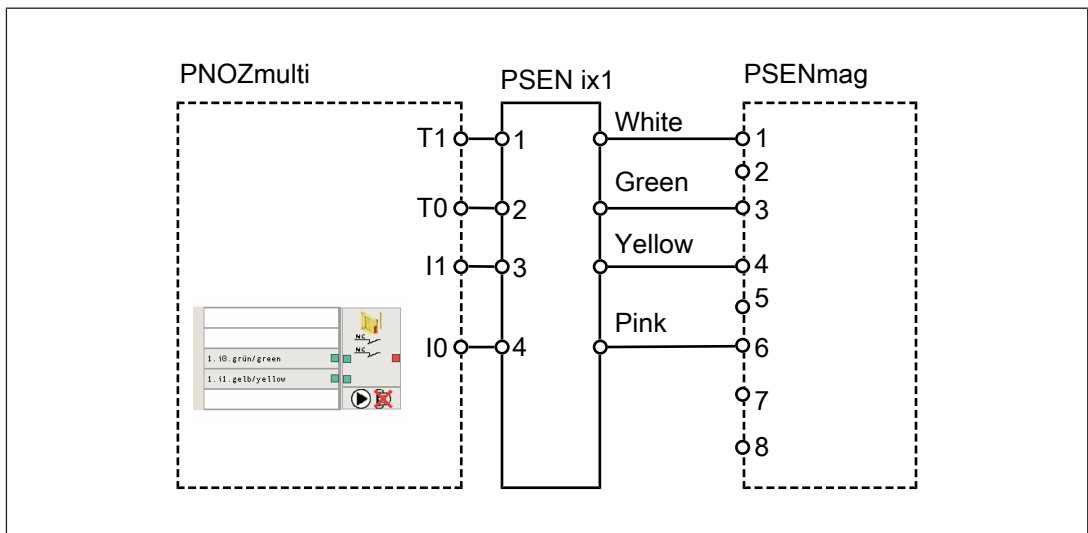
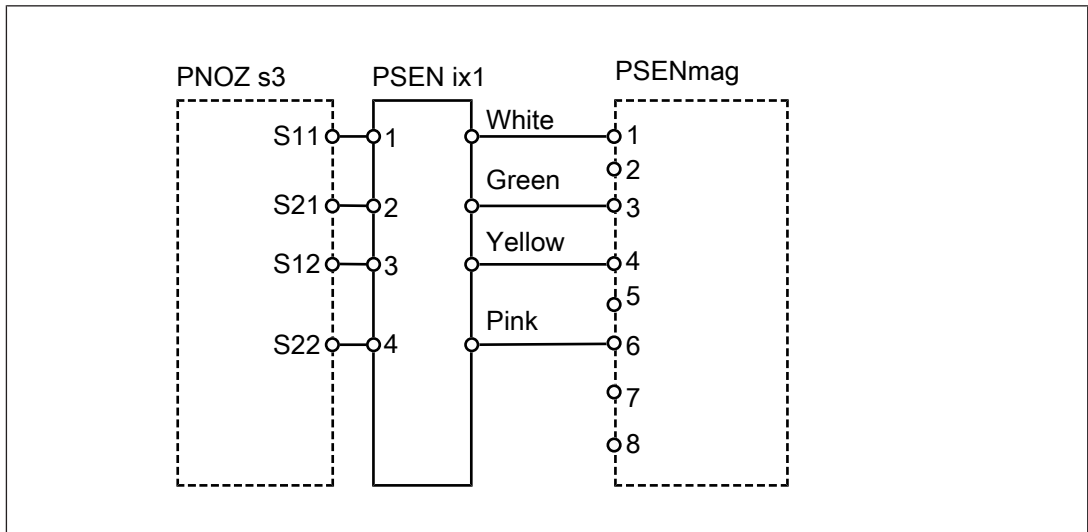

Fig.: Dual-channel connection of four PSENmag to the input circuits of an evaluation device

Examples for connection to Pilz evaluation devices:

Application in series connections



Application in single connections

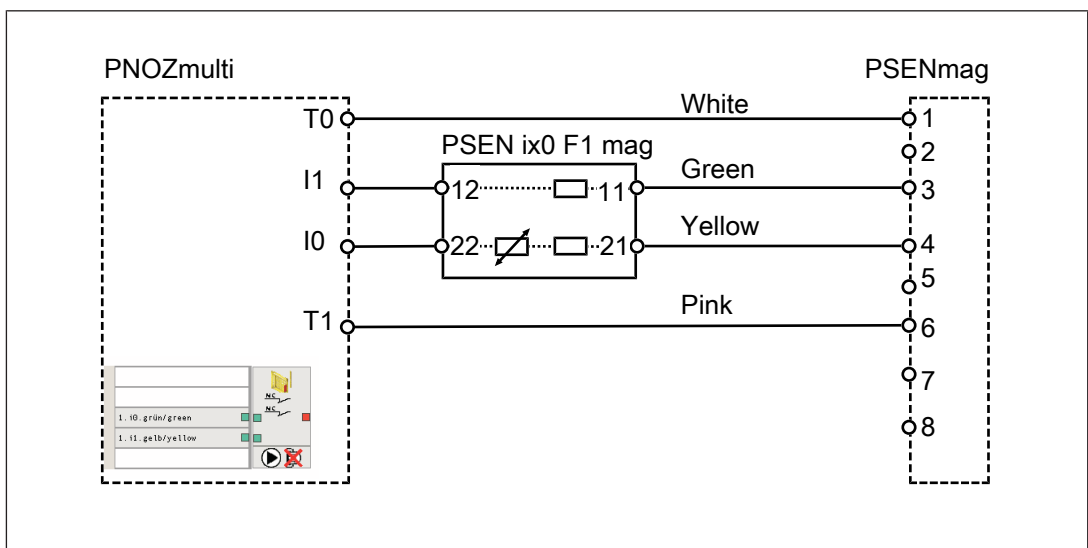
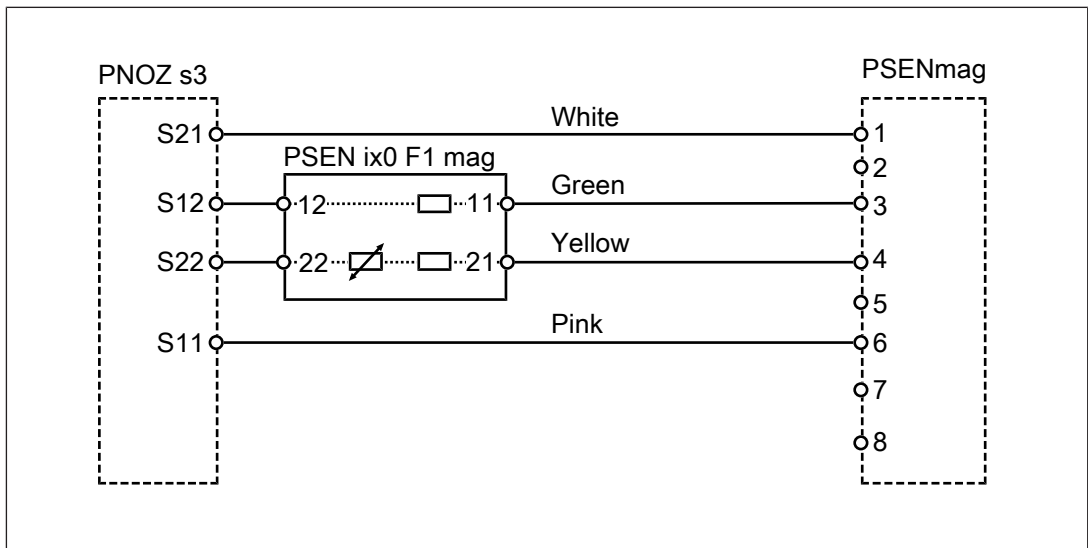

Installation

- ▶ The unit can be installed in any position. Safety switches and actuators must be installed so that the sensing face of the safety switch is exactly opposite the sensing face of the actuator.
- ▶ If possible, do not install the safety switch and actuator on to ferromagnetic material. Changes to the operating distances are to be expected.

**CAUTION!****Potential loss of safety function due to changed device properties**

The unit's properties may be affected if installed in an environment containing electrically or magnetically conductive material.

- Please check the operating distances and the assured release distance.

**CAUTION!****Possible loss of the safety function by changing the release distance S_{ar} with non-flush installation**

Installing the safety switch non-flush within electrically or magnetically conductive material, the value for the assured release distance S_{ar} can change.

- Check the assured release distance S_{ar} .

- ▶ Safety switches and actuators must be positioned so that they are secured against a change of position.
- ▶ The safety switch and actuator should only be secured using screws and nuts made of non-magnetic material (e.g. brass or stainless steel).
- ▶ Avoid the risk of damages from foreseeable external influences by attaching the safety switch and actuator. If necessary, safety switch and actuator have to be protected.

**INFORMATION**

Protect the actuator from unauthorised removal (e.g. via a screw lock or concealed installation) and from contamination.

- ▶ Prevent self-loosening of the fastening elements of safety switch and actuator.
- ▶ The fastening of safety switch and actuator has to be sufficiently stable to ensure the proper operation of the safety switch and the actuator.
- ▶ The distance between two safety switches must be maintained (see [Technical details \[18\]](#)).
- ▶ Safety switches and actuators
 - Should be kept away from iron swarf
 - Should not be exposed to strong magnetic fields
- ▶ Prevent the safety switch and actuator being exposed to heavy shock or vibration.
- ▶ Make sure that the safety switch and actuator cannot be used as an end stop.
- ▶ Circumvention of the safety switch in a reasonably foreseeable manner must be prevented.
- ▶ Please note the installation measures in accordance with EN ISO 14119 for a proximity switch type 4 with coding level Low.

- ▶ Alignment errors of the guard must not adversely affect the safety function of the guard.
- ▶ The assured operating distance S_{ao} and the assured release distance S_{ar} must be tested under real conditions.
- ▶ Do not apply any installation tools (e.g. Pliers) on the surfaces of the switch.
- ▶ The protection type (see [Technical details \[18\]](#)) is only achieved when Pilz connection cables are used - these are available as an accessory - and when the connector torque is complied with (see Technical details).

Application in series connections

- ▶ Install the interface PSEN ix1 in the control cabinet and wire the interface with the evaluation device (see [Wiring \[10\]](#)).



Application in single connections

- ▶ Install the control cabinet terminal PSEN ix0 F1 mag in the control cabinet and wire the control cabinet terminal with the evaluation device (see [Wiring \[10\]](#)).

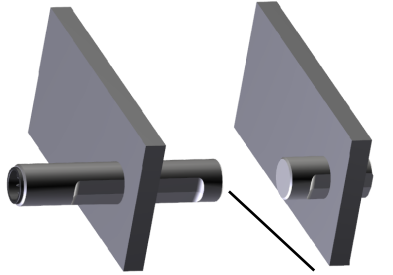
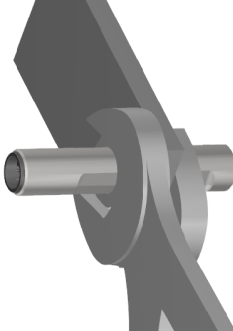
Installation of safety switch

 <p style="text-align: center;">Sensing face</p>	<p>Slide the switch through the hole in the mounting surface with the sensing face towards the actuator.</p>
	<p>Attach the switch using 2 M12x1 hexagonal nuts.</p> <p>The surfaces of the switch are not suitable for applying an installation tool (e.g. pliers).</p> <p>Also note the max. torque setting (see Technical details [18]).</p>

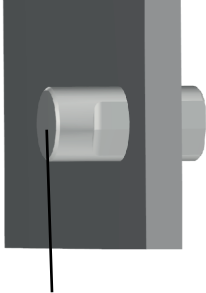
Installation with actuator PSEN ma1.3-08/VA

 <p>Sensing face</p>	<p>Slide the actuator through the hole in the mounting surface with the sensing face towards the safety switch.</p>
	<p>Attach the actuator using 2 M12x1 hexagonal nuts.</p> <p>Also note the max. torque setting (see Technical details [18]).</p>

Adjustment

Application in series connections

- ▶ The safety switch may only be used with the corresponding actuator PSEN ma1.3-08 VA.
- ▶ Always test the function with the PSEN ix1 interface and connected evaluation device.
- ▶ The stated operating distances (see [Technical details \[18\]](#)) only apply when the safety switch and actuator are installed according to the specifications [Installation \[15\]](#). Operating distances may deviate if other arrangements are used. Note the maximum permitted lateral and vertical offset (see [Operating distances and Lateral and vertical offset \[8\]](#)).

Application in single connections

- ▶ The safety switch may only be used with the corresponding actuator PSEN ma1.3-08 VA.
- ▶ Always test the function with the control cabinet terminal PSEN ix0 F1 mag and connected evaluation device.
- ▶ The stated operating distances (see [Technical details \[18\]](#)) only apply when the safety switch and actuator are installed according to the specifications [Installation \[15\]](#). Operating distances may deviate if other arrangements are used. Note the maximum permitted lateral and vertical offset (see [Operating distances and Lateral and vertical offset \[8\]](#)).

Periodic test

- ▶ Carry out a monthly function test on the safety switch and actuator.
- ▶ The safety function may only be checked by qualified personnel.

**NOTICE**

The safety function should be checked after initial commissioning and each time the plant/machine is changed. The safety functions may only be checked by qualified personnel.

Application in series connections

- ▶ Always test the function with the PSEN ix1 interface and connected evaluation device.

Application in single connections

- ▶ Always test the function with the control cabinet terminal PSEN ix0 F1 mag and connected evaluation device.

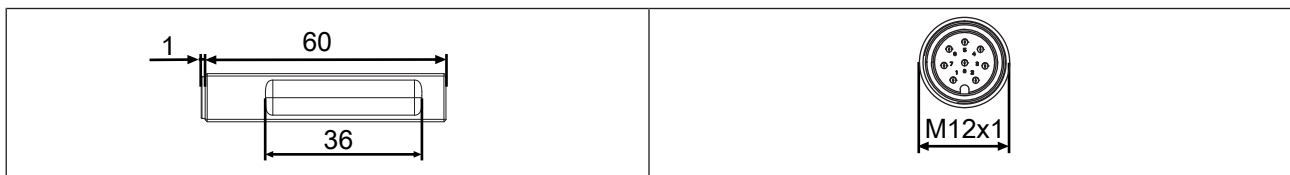
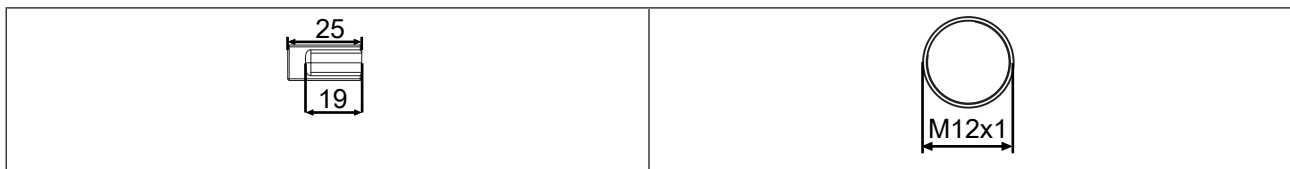
Dimensions in mm**Safety switch****Actuator PSEN ma1.3-08/VA****Technical details**

General	
Certifications	CE, EAC (Eurasian), ECOLAB, TÜV, UL/cUL
Sensor's mode of operation	Magnetic
Coding level in accordance with EN ISO 14119	Low
Design in accordance with EN ISO 14119	4
Classification in accordance with EN 60947-5-3	PDDB
Electrical data	
Supply voltage	
Voltage	24 V
Kind	DC
Voltage tolerance	-20 %/+20 %
Max. switching frequency	1 Hz
Lowest operating current (I _m)	1 mA
Max. voltage drop (U _d)	0,5 V

Electrical data	
Switching voltage	24 V
Internal resistance safety contacts	0 Ohm
Internal resistance auxiliary contact	0 Ohm
Max. switching current, safety contacts	0,14 A
Max. breaking capacity, safety contacts	4 W
Max. switching current, auxiliary contacts	140 mA
Utilisation category in accordance with EN 60947-1	DC-12
Conventional thermal current auxiliary contact	0,1 A
Max. continuous current safety contacts	0,1 A
Times	
Reaction time (actuator removed)	2 ms
Environmental data	
Ambient temperature	
Temperature range	-25 - 120 °C
Max. temperature in accordance with UL	-25 - 105 °C
Climatic suitability	
In accordance with the standard	IEC 60068-2-30
Humidity	90 % r. h. at 40 °C
Max. operating height above sea level	4000 m
EMC	EN 60947-5-3
Vibration	
In accordance with the standard	EN 60947-5-2
Frequency	10 - 55 Hz
Amplitude	1 mm
Shock stress	
Acceleration	30g
Duration	11 ms
Airgap creepage	
Pollution degree	3
Rated insulation voltage	30 V
Rated impulse withstand voltage	0,8 kV
Protection type	
Housing	IP67, IP69
Mechanical data	
Actuator 1	PSEN ma1.3-08 VA
Typ. Hysteresis	3 mm
Operating distances	
Assured operating distance Sao	8 mm
Min. operating distance Somin	0,5 mm
Typical operating distance So	10 mm
Assured release distance Sar	18 mm
Typical release distance Sr	13 mm
Repetition accuracy switching distances	5 %
Min. distance between safety switches	25 mm

Mechanical data	
Sensor flush installation in accordance with EN 60947-5-2	Yes, follow installation guidelines
Connection type	M12, 8-pin male connector
Material	
Top	Stainless steel 1.4401
Max. torque setting	
Safety switch	20 Nm
Actuator 1	20 Nm
Connector	0,6 Nm
Dimensions	
Height	12 mm
Width	12 mm
Depth	61 mm
Actuator dimensions	
Height	12 mm
Width	12 mm
Depth	25 mm
Weight of safety switch	20 g
Weight of actuator	10 g
Weight	30 g

Where standards are undated, the 2017-09 latest editions shall apply.

Safety characteristic data



NOTICE

You must comply with the safety characteristic data in order to achieve the required safety level for your plant/machine.

Operating mode	B10d in accordance with EN ISO 13849-1: 2015 and EN 62061	TM [year] in accordance with EN ISO 13849-1:2015
2-channel, > 15 mA	34.000.000	20
2-channel, ≤ 15 mA	50.000.000	20

Supplementary data

Technical details PSEN ix0 F1 mag

General	
Certifications	CE
Electrical data	
Internal resistance	10 Ohm

Environmental data	
Ambient temperature	
Temperature range	-10 - 55 °C
Storage temperature	
Temperature range	-25 - 70 °C
Protection type	
Housing	IP20
Mechanical data	
Connection type	Spring-loaded terminal
Conductor cross section with spring-loaded terminals: Flexible with/without crimp connector	0,08 - 2,5 mm², 28 - 14 AWG
Stripping length with spring-loaded terminals	5 - 6 mm
Dimensions	
Height	56 mm
Width	7 mm
Depth	91 mm
Weight	25 g

Order reference

System

Product type	Features		Order no.
PSEN ma1.3-22 M12/8/PSEN ma1.3-08	Magnetic safety switch, round actuator, with assured operating distance 8 mm	8-pin M12 male connector	506 247
PSEN ma1.3-22 M12/8/IX/VA/1switch	Magnetic safety switch	8-pin M12 male connector	526 247
PSEN ma1.3-08/ VA/1actuator	Actuator, with assured operating distance 8 mm		516 140

Accessories

Cable

Product type	Features	Connector X1	Connector X2	Connector X3	Order no.
PSEN cable M12-8sf VA 5m	5 m	M12, 8-pin female connector, straight, stainless steel threaded ring			533 190
PSEN cable M12-8sf VA 10m	10 m	M12, 8-pin female connector, straight, stainless steel threaded ring			533 191

Series connection

Product type	Features		Order no.
PSEN ix1 Interface for 4 PSEN 1	Interface PSEN ix1 for connecting and evaluating several safety switches PSEN ma		535 120

Single connection

Product type	Features		Order no.
PSEN ix0 F1 mag	Control cabinet terminal for use of the PSEN ma1.3-22 M12/8 VA in single connections		535 109

EC declaration of conformity

This product/these products meet the requirements of the directive 2006/42/EC for machinery of the European Parliament and of the Council. The complete EC Declaration of Conformity is available on the Internet at www.pilz.com/downloads.

Authorised representative: Norbert Fröhlich, Pilz GmbH & Co. KG, Felix-Wankel-Str. 2, 73760 Ostfildern, Germany